

RELIABILITY AND VALIDITY OF SCALE MEASURING MOTORCYCLISTS' RISK PERCEPTION: THE CASE STUDY OF HANOI, VIETNAM

Vuong Xuan Can^{1,2*}, Mou Rui-Fang¹, Vu Trong Thuat², Nguyen Thi An³

¹*School of Transportation and Logistics, Southwest Jiaotong University, China*

²*University of Transport and Communications, Vietnam*

³*National Economics University, Vietnam*

*Corresponding author: vuongcan@utc.edu.vn; vuongcan@gmail.com

(Received: September 23, 2022; Revised: February 13, 2023; Accepted: February 14, 2023)

Abstract - The purposes of this study are to test and verify a risk perception scale among Vietnamese motorcyclists using Cronbach's Alpha coefficient, Exploratory Factor analysis (EFA), and Confirmatory Factor Analysis (CFA) through a self-reported questionnaire. The risk perception scale is established to measure the risk perception of motorcyclists in Hanoi. The scale consists of 14 items, which are divided into three factors: Worry and Concern, Probability Assessments, and Cognition of Danger level. These factors can explain 71.586% of the variation. The factor loadings of items all meet the requirements of the tests. The risk perception scale has good reliability and validity and can be used to measure the risk perception of Vietnamese motorcyclists. The results of this study can inform the future study of risk perception and risky behaviors of Vietnamese motorcyclists.

Key words - Vietnamese motorcyclists; self-reported questionnaire; risk perception; Confirmatory Factor Analysis (CFA); Exploratory Factor Analysis (EFA)

1. Introduction

World Health Organization statistics for road accidents worldwide show that the number of deaths from road traffic accidents (RTAs) is around 1.35 million per year [1]. The majority of fatal accidents are motorcyclists in developing countries like Vietnam where motorcycles are the most frequent means of transportation [2]. For example, in Vietnam, RTAs caused by motorcyclists account for over 59.4% of RTAs, and involving awareness of traffic participants accounted for 80.1% [3]. Hence, motorcycle safety is still a major issue around the world, notably in developing countries like Vietnam.

Many scholars have indicated that risk perception has related to risky behavior in general [4], and is also closely related to RTAs. Up to now, scholars have paid less attention to the risk perception of motorcyclists in comparison to car drivers. Besides, a few studies have been done regarding the risk perception of motorcyclists in Vietnam and how it contributes to risky behaviors and RTAs. This study preliminarily tests and confirms a risk perception scale of motorcyclists in Vietnam. At the same time, we attempt to explain the relationship among risk perception's detected factors which are verified using EFA and CFA.

This study can be used to create a self-reported survey of motorcyclists which is not only used to investigate the risk perception of motorcyclists but can also be applied to pre-evaluate risk perception in riding training and testing activities. This study also provides a powerful predictive tool for motorcyclists' risk perception and a scientific basis for the professional safety education of motorcyclists.

2. Literature review

Risk perception has described the concept of driving as "the subjective experience of risk in potential traffic hazards" [5]. People with a high level of risk perception are more likely to behave cautiously and carefully. RTAs are strongly correlated with poor risk perception [6]. Risk perception can be measured by cognitive probability and concern of consequences, i.e., the probability and consequence severity regarding RTAs are important for the concept of risk perception [7-9]. Rundmo and Iversen developed a risk perception scale with 3 different factors, including Worry and Insecurity (4 items), Probability assessments (4 items), and Concern (2 items) to examine the relationship between risk perception and behaviors of adolescents in two Norwegian counties [10]. The factors of Worry and Concern are related to worry and concern about traffic injury and accident risk (e.g., Feeling unsafe that you could be injured in a traffic accident while riding; Feeling unsafe that persons could be injured in a traffic accident). Probability assessments include the probabilities for the respondent himself or herself relate to injuries caused by RTAs as well as worry and concern, i.e. affect when thinking of traffic risks (e.g., How probable do you think it is for yourself to be injured in a traffic accident). Machin and Sankey used four factors, involving Worry and Concern (6 items adapted from Rundmo and Iversen [10]), Likelihood of a Crash (3 items), Efficacy (5 items), and Aversion to Risk Taking (8 items) to measure risk perception of young car drivers in the University of Southern Queensland [11, 12]. The items of Likelihood of a Crash indicate the possibility of an accident for respondents and others in the future (e.g., please rate your chances of having an accident within the next 12 months). The items of Efficacy measure the extent of confidence of respondents about driving in certain conditions (e.g., how confident are you about driving on unfamiliar roads?). The items of Aversion to Risk Taking measure how dangerous respondents thought certain actions are while driving (e.g., violating red lights). Ma et al. measured the risk perception of taxi and bus drivers in China through three factors of 10 items, Worry and Insecurity, Likelihood of a Crash, and Concern based on the study of Rundmo and Iversen [13]. Wang et al. also used 3 different factors of 11 items, including Level of Danger, Concern, and Probability assessments to examine the risk perception of electric riders in China [14, 15]. The items of Level of Danger are similar to those of Machin's Aversion to Risk

Taking. Probability assessments and Concerns are based on the scale of Rundmo and Iversen. The researchers found that Worry and Concern, Probability assessments, and Aversion to Risk Taking are the affecting factors that are commonly used to measure risk perception. However, most previous studies that measure the risk perception of car drivers were conducted in developed countries.

In Vietnam, there were only a few studies that focused on the given behaviors of motorcyclists as well as affecting factors of risk behaviors of motorcyclists, such as risk perception, riding attitudes, etc. For example, Nguyen et al. [16] examined a relationship between risk behaviors and risk perception, and they had no link between them. Their scale of risk perception was not verified in Vietnamese motorcyclists. Nguyen-Phuoc et al. [17] pointed out some factors that affected the frequency of turn signals at intersections, such as environmental characteristics, perceived risk, and beliefs. Their perceived risk scale only was measured by two items from a previous study. Nguyen-Phuoc et al. [18] investigated some factors related to the risk-taking attitude, and road safety compliance of motorcycle delivery riders, such as job demands and resources. However, they did not consider the risk perception of motorcycle riders. Vuong et al. [19] initially explored riding attitudes and attempt to explain the relationship between the detected factors among riding attitudes based on a self-reported questionnaire. It can be seen that very few studies focus on the reliability and validity of the risk perception scale before conducting related works.

3. Materials and Methods

3.1. Data Collection

This study uses a self-reported questionnaire to examine the risk perception of motorcyclists in Vietnam. The self-reported questionnaire consists of general demographics (e.g., gender, age, riding license) and questions related to the risk perception of Vietnamese motorcyclists based on related previous studies of risk perception. All items of the self-reported questionnaire from previous studies are first translated into Vietnamese [10, 14, 15, 20, 21]. After that, the items that do not conform to the situation in Vietnam are removed. Finally, a self-reported questionnaire of risk perception containing 14 items is formed which is divided into 3 different factors, including Worry and Concern (4 items), Probability assessments (4 items), and Cognition of danger level (6 items). Quantitative items are assessed through a 5-level scale ranging from low to high (strongly disagree/no danger (1) to strongly agree/very dangerous (5)), the higher the score, the more worried about traffic risks and feelings. The higher the risk of behavior is subjective, the greater the perceived consequences.

We selected to interview motorcyclists in specific areas, such as registration locations, commercial centers, agencies, schools, etc. in Hanoi City, the capital of Vietnam. Respondents are those over 16 years old who are capable and experienced in riding with or without a riding license.

3.2. Hypothesis testing

The hypotheses include: (H1) The questionnaire is appropriately used to study the risk perception of Vietnamese motorcyclists. The goodness-of-fit index (GFI) and the root mean square error of approximation (RMSEA) are evaluated as absolute fit measures. The comparative fit index (CFI) [22] and incremental fit index (IFI) are taken as incremental fit indexes. Other indexes are used to test the hypothesis, such as the value of Chi-square/df, and the Tucker-Lewis index (TLI). The criteria of goodness-of-fit statistics are required as follows [23, 24]: The value of chi-square/df < 5, GFI \geq 0.8, RMSEA < 0.08, CFI \geq 0.9, TLI \geq 0.9, IFI \geq 0.9.

To filter observed variables of the same group and eliminate some factors to fit with the model, we utilize exploratory factor analysis (EFA) to develop hypothesized measurement models before testing by confirmatory factor analysis. Second-order confirmatory factor analysis (second-order CFA) is utilized to create a model confirming riding behavior measurement and to select variables and factors that could be used in a self-reported questionnaire. In this study, SPSS software is used for descriptive statistics, including EFA, EFA, and reliability tests with Cronbach's Alpha coefficient. The questionnaire items are analyzed EFA using principal components analysis and oblique rotation of varimax. Further, AMOS software as the tool for structural equation modeling is utilized for Confirmatory factor analysis (CFA) with a multiple-item measurement model to evaluate unidimensionality for sets of measurement items and the identified adequacy of the factorial structure.

4. Analysis results

4.1. Sample Characteristics

After data collection from January to March 2019 with 716 valid questionnaires, the information of the valid questionnaires was processed into SPSS and AMOS software for post-processing. The respondents were males (52.5%) and females (47.5%). Most of them (50%) were 16–25 years old. Of the respondents, 85.1% had a riding license for a motorcycle while 14.9% did not. Regarding education level, 33.2% of the respondents had a college and intermediate level or less and 66.8% of the surveyed respondents had a university degree or higher. Regarding income, 42.8% of respondents had 5-10 million VND per month; 51.7% had below 5 million per month and the remaining nearly 5.9% of respondents had over 10 million per month. Regarding employment, students accounted for 38.8%; workers and employees accounted for 21.9%; government employees accounted for 20%; the rests were others. Regarding marital status, married with having children accounted for 20.1%, married with no children accounted for 13.1% and the rests were unmarried. Regarding riding experience, 21% of the respondents had under 3 years of riding experience; 23% of the respondents had 3-5 years of riding experience; 23.5% of the respondents had 5-7 years of riding experience; the rest had over 7 years of riding experience. The statistical results of the items showed that the mean was 2.64–4.18, and the standard deviation (SD) was between 0.959 and 1.383, as shown in Table 1.

Table 1. Risk perception scale

No	Item	Symbol	Mean	SD	Related Studies
	Worry and Concern	WC			
1	Feeling unsafe that you yourself could be injured in a traffic accident while riding	WC01	3.35	0.959	[10, 14]
2	Worried for yourself being injured in a traffic accident	WC02	3.43	0.972	[10]
3	Feeling unsafe that persons could be injured in a traffic accident	WC03	3.47	0.997	[10]
4	Concerning about a traffic accident and thinking that you yourself could be victimized	WC04	3.55	1.051	[14]
	Probability assessments	PA			
5	How probable do you think it is for yourself to be involved in a traffic accident	PA01	2.64	1.341	[10, 14]
6	How probable do you think it is for yourself to be injured in a traffic accident	PA02	2.72	1.329	[10, 14]
7	How probable do you think that you are more likely to have a traffic accident than others?	PA03	2.67	1.360	[14]
8	How probable do you think that riding a motorcycle in a traffic accident is higher than that of other vehicles	PA04	3.08	1.383	New item
	Cognition of danger level	CD			
	Riders were asked how dangerous they thought each item would be				
9	Violating red lights	CD01	3.64	1.007	[14]
10	Riding after drinking alcohol beyond the legal limit	CD02	4.18	1.068	[14]
11	Ride faster than surrounding riders	CD03	3.85	1.085	[14]
12	Going in the opposite direction	CD04	3.96	1.097	[20]
13	Get into the wrong lane	CD05	3.85	1.085	[21]
14	Use a cell phone whilst riding	CD06	3.88	1.193	New item

4.2. Analysis results

4.2.1. Exploratory factor analysis (EFA)

Table 2. Results of the EFA and reliability test of risk perception

Item	Factor			α	Corrected Item-Total Correlation
	DC	PA	WC		
WC01			0.834	0.877	0.722
WC02			0.884		0.782
WC03			0.807		0.751
WC04			0.734		0.688
PA01		0.886		0.913	0.824
PA02		0.926			0.874
PA03		0.902			0.844
PA04		0.757			0.676
CD01	0.693			0.884	0.628
CD02	0.740				0.636
CD03	0.790				0.707
CD04	0.834				0.767
CD05	0.811				0.733
CD06	0.782				0.715
Eigenvalues	3.828	3.282	2.912		
Variance explained (%)	27.342	23.442	20.803		
Cumulative Variance explained (%)	27.342	50.784	71.586		

There were 14 such items for the analysis process of the measurement model for Risk Perception (RP) and we achieved 3 factors with the KMO (Kaiser-Meyer-Olkin) of 0.875 ($>0,5$) and Sig of 0.000 (<0.05), including Worry and Concern (WC), Probability assessments (PA), and

Cognition of danger level (CD). The factor loading coefficients are all greater than 0.5, and are all unidirectional, as shown in Table 2. The cumulative variance explained was 71.586% (larger than 50%). That was appropriate for analysis reliability and the CFA.

4.2.2. Reliability test

The results of the reliability test using the Cronbach's Alpha coefficient show that no original observed variables are excluded and the Cronbach's Alpha coefficient of the three factors is in the range of 0.877~0.913 (>0.6) and the minimum of the Corrected Item-Total Correlation is 0.628 (larger than 0.3), showing that these scales have high reliability, as shown in Table 2.

4.2.3. Confirmatory factor analysis (CFA)

After the EFA process, there were three factors of risk perception (RP), including Worry and Concern (WC), Probability assessments (PA), and Cognition of danger level (CD) for measuring motorcyclists' risk perception with 14 items. We performed the second-order CFA model testing on AMOS software, corresponding to a significance level of each item being 0.01. The first results of the second-order CFA model showed that the standardized factor loadings of the items are in the range of 0.631~0.831 (larger than 0.5 [24]) and the goodness-of-fit statistics were obtained the requirements. The results of goodness-of-fit statistics were Chi-square = 326.516 and $df = 70$. Therefore, the second-order CFA model had the value of Chi-square/ $df = 4.665$, which was lower than 5 [25]. Furthermore, $P < 0.001$, GFI = 0.938 > 0.9 , TLI = 0.948 > 0.9 ,

CFI = 0.960 > 0.9, RMSEA = 0.072 < 0.08, which met the criteria, as shown in Figure 1

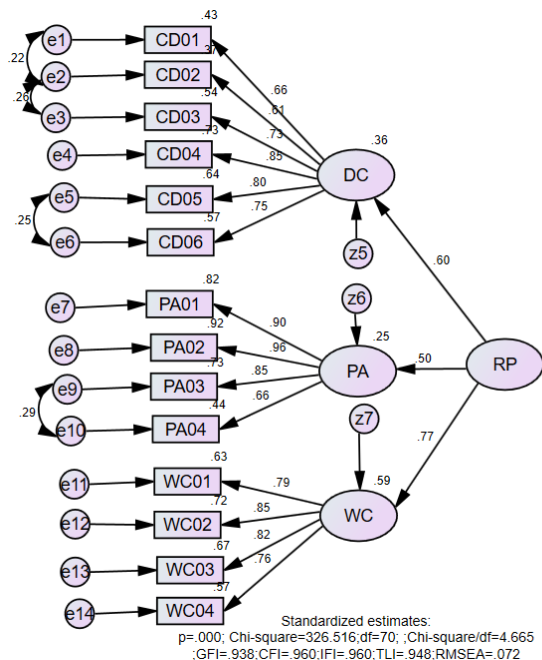

Figure 1. Measurement model for risk perception by the second-order CFA

Besides, to ensure reliability and convergence, the Average Variance Extracted (AVE) is not less than 0.5 [26] and the composite reliability index (CRI) is not less than 0.6 [27, 28]. The CRI values from Worry and Concern (WC), Probability assessments (PA), and Cognition of danger level (CD) were 0.88, 0.91, and 0.88, respectively. The AVE values from Worry and Concern (WC), Probability assessments (PA), and Cognition of danger level (CD) were 0.65, 0.73, and 0.55, respectively. All the CRI and the AVE values met the analysis criteria. Besides, the values of the critical ratio (C.R.) are larger than 1.96 [24], indicating that the significance level of the estimated coefficients is guaranteed, as shown in Table 3.

Table 3. The results of the second-order CFA model

Item	Estimate	S.E.	C.R.	p-value	Std. Estimate	AVE	CRI
CD01	1				0.657		
CD02	0.782	0.049	16.043	***	0.61	0.55	0.88
CD03	0.996	0.06	16.645	***	0.732		
CD04	1.182	0.064	18.604	***	0.854		
CD05	1.12	0.063	17.715	***	0.801		
CD06	1.042	0.062	16.832	***	0.753		
PA01	1				0.905		
PA02	1.051	0.025	41.995	***	0.96		
PA03	0.957	0.029	33.381	***	0.854		
PA04	0.754	0.036	21.082	***	0.662		
WC01	1				0.793	0.65	0.88
WC02	1.082	0.045	23.955	***	0.847		
WC03	1.069	0.046	23.043	***	0.816		
WC04	1.043	0.05	21.044	***	0.755		

Note: Std. Estimate - Standardized estimate; *** - significant at 0.001 level; C.R. - critical ratio; S.E. - standard error; p-value - probability.

The analysis of the EFA and the CFA for items showed that the Vietnamese motorcyclists' risk perception (RP) can be grouped into three factors, including Worry and Concern (WC), Probability assessments (PA), and Cognition of danger level (CD) through 14 items. The standardized estimates of WC, PA, and CD are 0.77, 0.50, and 0.6, respectively (Figure 1). They are all equal to and greater than 0.5 [19, 24], indicating that the correlation between first-order factors (i.e., WC, PA, and CD) and the second-order factor (i.e., RP) is strong and supports the existence of the second-order factor RP, as well as indicating that the structure of the second-order factor model of risk perception of motorcyclists is reasonable.

The values of goodness-of-fit statistics for the second-order CFA model met all the criteria for hypothesis testing. The estimation results of the model parameters of the second-order CFA model showed that the questionnaire is appropriate to study the risk perception of a Vietnamese person (i.e., H1 accepted).

The results in Table 1 show that the awareness of motorcyclists about traffic risk is quite high in general (the maximum score of 4.18 and the minimum score of 2.64). It shows that all items are rated with a mean of 2.5 or higher. This also reflects that the respondents are quite worried and concerned about traffic risks, moreover, are also aware of the risks of some offenses.

Cronbach's Alpha for three factors (WC, PA, and CD) of risk perception in Table 2 are 0.877, 0.913, and 0.884 respectively. These are all very high values and are also consistent with previous studies ([10], [15]). Besides, these factors account for 71.586% of the total variance which is higher than that of previous studies ([15]). Hence, they show that there is good internal consistency and discriminant validity of the questionnaire in Vietnam.

The risk perception scale can be measured by 3 factors, including DC, PA, and WC. This is the first found in the traffic environment in Vietnam. It can be used to build relationships between risk perception and safety attitudes, and risk behaviors of motorcyclists in Vietnam. It can also be used in riding training to improve awareness of traffic safety. Moreover, it can help inform the development of more targeted measures to increase the risk perception of motorcyclists in Vietnam.

5. Conclusions

In this study, we aimed to test and confirm the risk perception scale of Vietnamese motorcyclists based on previous studies. This research showed that this scale was appropriate for Vietnamese motorcyclists with 14 items from three factors (WC, PA, and CD) which were consistent with the factors found in other countries, but based on the best of our knowledge, a multi-item questionnaire has not been tested in Vietnam yet. The results are to provide a reliable measurement for further research. Besides, the results can be used to create a riding self-report of motorcyclists before the exams.

The limitation of this study consisted of the place (i.e. Hanoi City, Vietnam). In future works, we will

analyze the factors of risk perception in affecting risky behaviors and traffic accidents of motorcyclists in wider study areas.

Acknowledgment: This research is funded by the University of Transport and Communications (UTC) under grant number T2023-MT-002.

REFERENCES

- [1] WHO, "Global status report on road safety 2018", World Health Organization, 2018.
- [2] X.-C. Vuong, R.-F. Mou, H.-S. Nguyen, and T.-T. Vu, "Signal Timing Optimization of Isolated Intersection for Mixed Traffic Flow in Hanoi City of Vietnam Using VISSIM", *International Conference on Smart Vehicular Technology, Transportation, Communication and Applications*, 2018, pp. 133-139.
- [3] Traffic Police Department of Vietnam (TPD), "Traffic Safety Annual Reports (2019-2021)", Traffic Police Department of Vietnam, 2022.
- [4] L. D. Cohn, S. Macfarlane, C. Yanez, and W. K. Imai, "Risk-perception: differences between adolescents and adults", *Health Psychology*, vol. 14, no. 3, pp. 217-222, 1995.
- [5] H. A. Deery, "Hazard and risk perception among young novice drivers", *Journal of safety research*, vol. 30, no. 4, pp. 225-236, 1999.
- [6] T. Ram and K. Chand, "Effect of drivers' risk perception and perception of driving tasks on road safety attitude", *Transportation research part F: traffic psychology and behaviour*, vol. 42, pp. 162-176, 2016.
- [7] T. Rundmo, "Associations between affect and risk perception", *Journal of risk research*, vol. 5, no. 2, pp. 119-135, 2002.
- [8] L. Sjöberg, B.-E. Moen, and T. Rundmo, "Explaining risk perception. An evaluation of the psychometric paradigm in risk perception research", *Rotunde publikasjoner Rotunde*, vol. 84, pp. 55-76, 2004.
- [9] N. T. Brewer, G. B. Chapman, F. X. Gibbons, M. Gerrard, K. D. McCaul, and N. D. Weinstein, "Meta-analysis of the relationship between risk perception and health behavior: the example of vaccination", *Health psychology*, vol. 26, no. 2, pp. 136-145, 2007.
- [10] T. Rundmo and H. Iversen, "Risk perception and driving behaviour among adolescents in two Norwegian counties before and after a traffic safety campaign", *Safety science*, vol. 42, no. 1, pp. 1-21, 2004.
- [11] M. A. Machin and K. S. Sankey, "Factors influencing young drivers' risk perceptions and speeding behaviour", *Proceedings of the 2006 Australasian Road Safety Research, Policing and Education Conference*, 2006.
- [12] M. A. Machin and K. S. Sankey, "Relationships between young drivers' personality characteristics, risk perceptions, and driving behaviour", *Accident analysis & prevention*, vol. 40, no. 2, pp. 541-547, 2008.
- [13] M. Ma, X. Yan, H. Huang, and M. Abdel-Aty, "Occupational driver safety of public transportation: Risk perception, attitudes, and driving behavior", *Proceedings of the Transportation Research Board 89th Annual Meeting*, 2010, pp. 82-91.
- [14] T. Wang, "Electric bike rider the mechnism study on the risk driving behavior and accident", Southeast University, 2017.
- [15] T. Wang, S. Xie, X. Ye, X. Yan, J. Chen, and W. Li, "Analyzing E-bikers' risky riding behaviors, safety attitudes, risk perception, and riding confidence with the structural equation model", *International journal of environmental research and public health*, vol. 17, no. 13, pp. 4763, 2020.
- [16] V. L. Nguyen, T. L. Dao, D. P. Nguyen, V. L. Nguyen, M. D. Bui, and V. H. Pham, "Traffic Risk Perception, Risky Road Use Behaviors among Vietnamese People", *The Open Psychology Journal*, vol. 13, no. 1, pp.49-57, 2020.
- [17] D. Q. Nguyen-Phuoc, C. D. Gruyter, O. Oviedo-Trespalacios, D. N. Su, and A. T. P. Tran, "Turn signal use among motorcyclists and car drivers: The role of environmental characteristics, perceived risk, beliefs and lifestyle behaviours", *Accident Analysis and Prevention*, vol. 144, pp. 105611, 2020.
- [18] D. Q. Nguyen-Phuoc, N. A. N. Nguyen, M. H. Nguyen, L. N. T. Nguyen, and O. Oviedo-Trespalacios, "Factors influencing road safety compliance among food delivery riders: An extension of the job demands-resources (JD-R) model", *Transportation research part A: policy and practice*, vol. 166, pp. 541-556, 2022.
- [19] X. C. Vuong, R.-F. Mou, T. T. Vu, and T. T. A. Cu, "Exploring factors associated with riding attitudes of motorcyclists in Vietnam", *The Transport and Communications Science Journal*, vol. 74, no. 1, pp. 81-96, 2023.
- [20] J.-T. Wong, Y.-H. Chang, and S.-H. Huang, "Some insights of young motorcyclists' risky behavior", *Transportation Research Board 88th Annual Meeting, 09-2353*, 2009, pp.1-14.
- [21] J.-T. Wong, Y.-S. Chung, and L.-W. Hsiao, "Structure discrepancy of riding behavior of heterogeneous young motorcyclists in Taiwan", *Transportation research record*, vol. 2194, no. 1, pp. 107-114, 2010.
- [22] P. M. Bentler, "Comparative fit indexes in structural models", *Psychological bulletin*, vol. 107, no. 2, pp. 238, 1990.
- [23] X. C. Vuong, R.-F. Mou, T. T. Vu, and T. A. Nguyen, "A Study of Intended Unsafe Pedestrian Crossing Behaviors at Signalized Intersections in Vietnam", *Advances in 21st Century Human Settlements*, Springer, 2021, pp. 185-193.
- [24] L. T. Hu and P. M. Bentler, "Cutoff criteria for fit indexes in covariance structure analysis: Conventional criteria versus new alternatives", *Structural equation modeling: A multidisciplinary journal*, vol. 6, no. 1, pp. 1-55, 1999.
- [25] D. W. Gerbing and J. C. Anderson, "An updated paradigm for scale development incorporating unidimensionality and its assessment", *Journal of marketing research*, vol. 25, no. 2, pp. 186-192, 1988.
- [26] J. Hair, W. Black, B. Babin, and R. Anderson, *Multivariate Data Analysis 7th Edition*, Pearson Prentice Hall, 2009.
- [27] C. Fornell and D. F. Larcker, "Structural equation models with unobservable variables and measurement error: Algebra and statistics", Sage Publications, 1981.
- [28] J. F. Hair Jr, G. T. M. Hult, C. M. Ringle, and M. Sarstedt, *A primer on partial least squares structural equation modeling (PLS-SEM)*, Sage publications, 2016.